

CMB-37B

Mini Barebone system
Intel High Performance Platform
Installation Guide

Edition 1.0

2013/06/18



1

Document Content:

- Packing List
- Product Specification
- Hardware Installation

Packing List:

CMB-37B Chassis x 1
(Including LS-37B Motherboard)



DSPD-080-12A 80W AC-DC Adapter x 1



CPU Cooler x 1



PS/2 Keyboard & Mouse Cable x 1



DVI Adapter x1, DVI Cable x1



CMB-37B

COM PORT cable x 1



DC_IN Power Cable x 1

SATA (7P+15P)Cable x 1

CD Driver x1



Hardware Installation: <Motherboard placement>

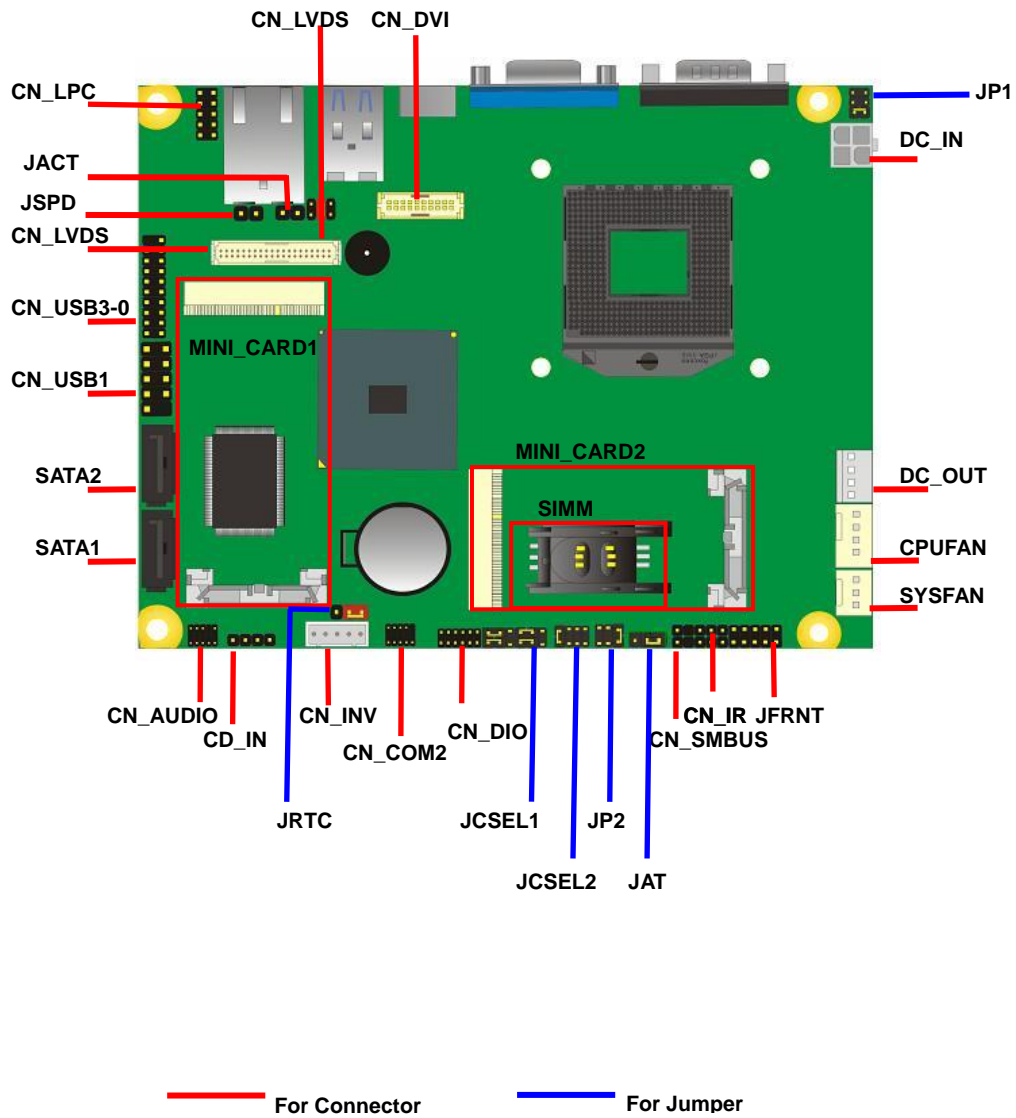

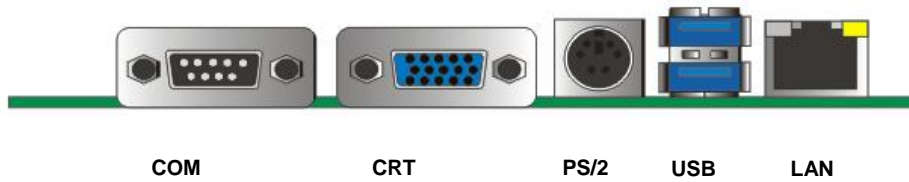
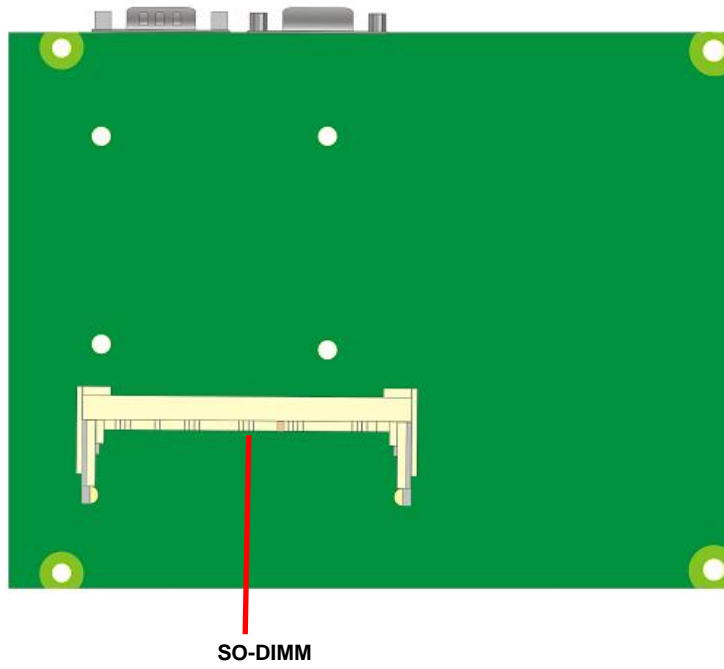

<Jumper Location & Reference>

Jumper	Function
JRTC	CMOS Operating/Clear Setting
JVLCD	Panel Voltage Setting
JAT	Power mode select
JP1	Com1 Voltage Setting (For Pin 9)
JP2	Com2 Voltage Setting (For Pin 9)
JCSEL1	CN_COM2 RS-232 RS422 RS485 Setting
JCSEL2	CN_IR IrDA Setting

Jumper: **JAT**

Type: onboard 3-pin header

Power Mode	JAT
AT Mode	1-2
ATX Mode	2-3
Default setting: ATX Mode	
	

Jumper: **JP1/JP2 (COM1/2)**

Type: onboard 6-pin header

Power Mode	JP1/2
<div style="text-align: center;"> 1 2 </div> 	1-2
<div style="text-align: center;"> 5 6 </div>	3-4
Standard COM port	5-6
	Default setting

Setting RS-232 & RS-422 & RS-485 for COM2

Jumper: **JCSEL1,JCSEL2**

Type: 12-pin (6 x 2) & 8-pin (4 x 2) for set COM2 mode jumper

	RS232	RS485	RS422	IrDA
JCSEL1				
JCSEL2				

Default: RS232

<Internal Connectors>

Connector	Function	Remark
CPU	Socket rPGA988B for PGA988 CPU	
SO-DIMM	204 -pin DDR3 SO-DIMM socket	
SATA 1/2	7-pin Serial ATAIII connector	
DC_IN	DC 9~24V input connector	
DC_OUT	4-pin DC output connector	
CN_AUDIO	5 x 2-pin audio connector	
CD_IN	4-pin CD-ROM audio input connector	
CN_DIO	6 x 2-pin digital I/O connector	
CN_USB 1/2	5 x 2-pin USB connector	
CPUFAN	4-pin CPU cooler fan connector	
SYSFAN	3-pin system cooler fan connector	
CN_DVI	10 x 2-pin DVI connector	
CN_LVDS	20 x 2-pin LVDS connector	
CN_INV	5-pin LCD inverter connector	
CN_IR	5-pin IrDA connector	
CN_COM2	9-pin RS232/485/422	
CN_LPC	5 x 2-pin LPC connector	
JFRNT	10-pin front panel switch/indicator connector	
Mini-PCIE1/2	52-pin Mini-PCIE socket	
JAT	Power mode select	
JSPD	LAN Speed LED connector	
JACT	LAN Activity LED connector	

<External Connectors>

Connector	Function	Remark
COM1	DB9 Serial port connector	
CRT	DB15 VGA connector	
PS2	PS/2 keyboard and mouse connector	
USB	Dual USB 3.0 connector	
RJ45	RJ45 LAN connector	

<CPU and Memory Setup>

The board comes with the socket rPGA988 for Intel **Ivy Bridge** Processor, Please follow the instruction to install the CPU properly.

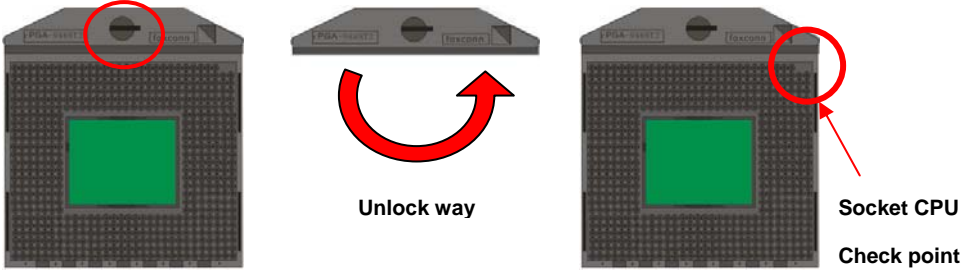

1. Use the flat-type screw drive to

2. Follow the pin

Check point

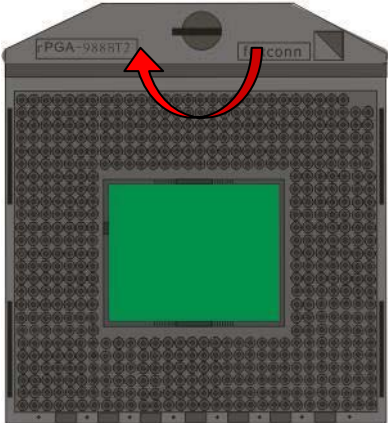

3. Lock the socket

2.4.2 <Memory Setup>

The board provides 1 x 204-pin DDR3 SO-DIMM to support 800/1066MHz DDR3 memory module up to 4GB.

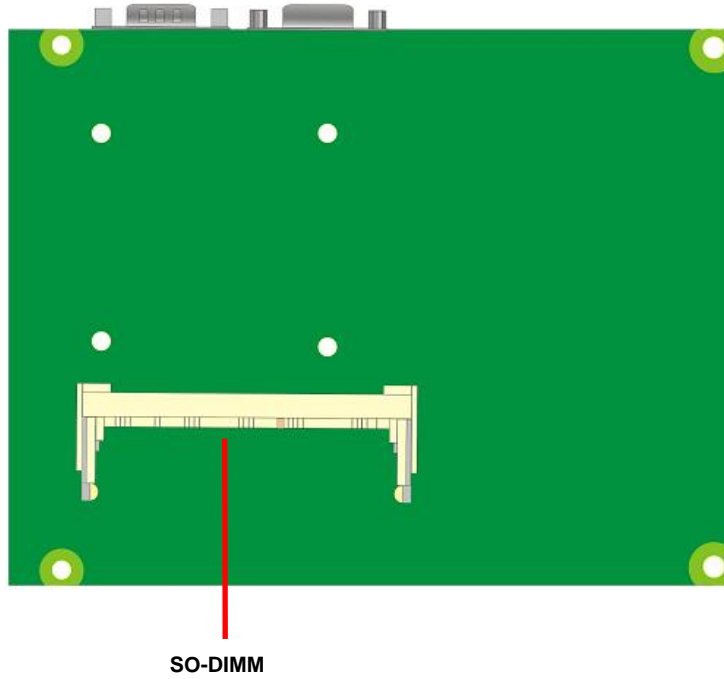

I/O panel:

Front:

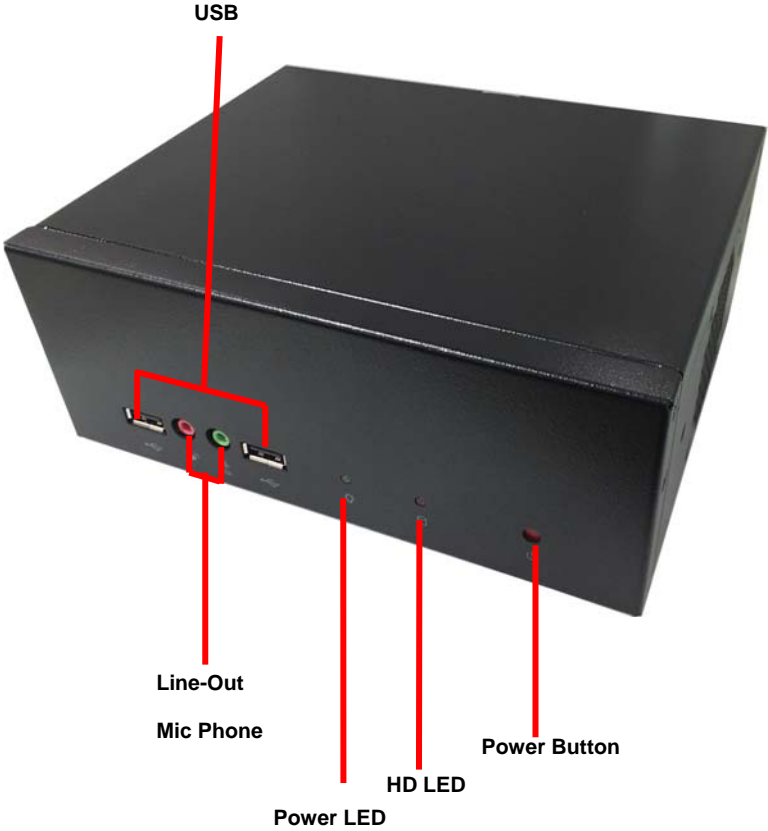

Rear panel:

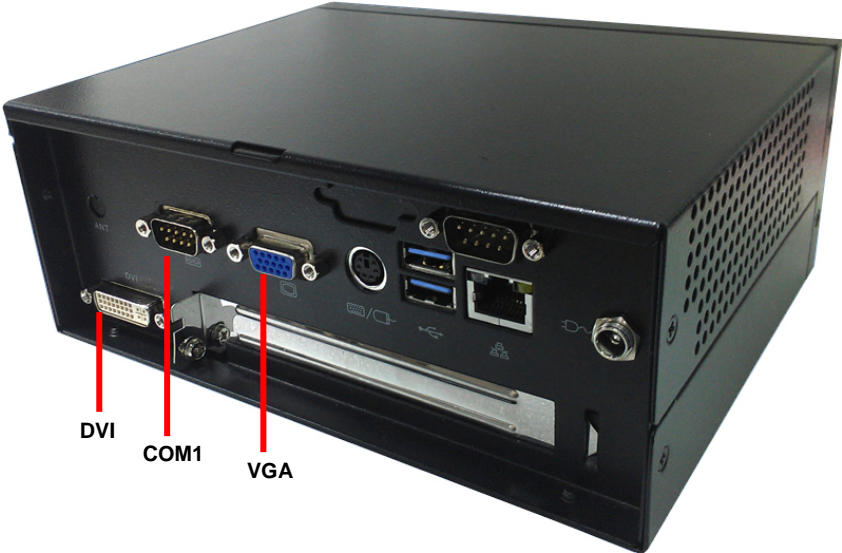

Chassis Setup procedure:

1. Screw off as indication of the picture below.



2. Push the Chassis shield towards the back then open it.



3. Turn the CPU cooler screws and then refer the page.9 to install the CPU.(After installing CPU, please turn the CPU FAN screws to tighten.)

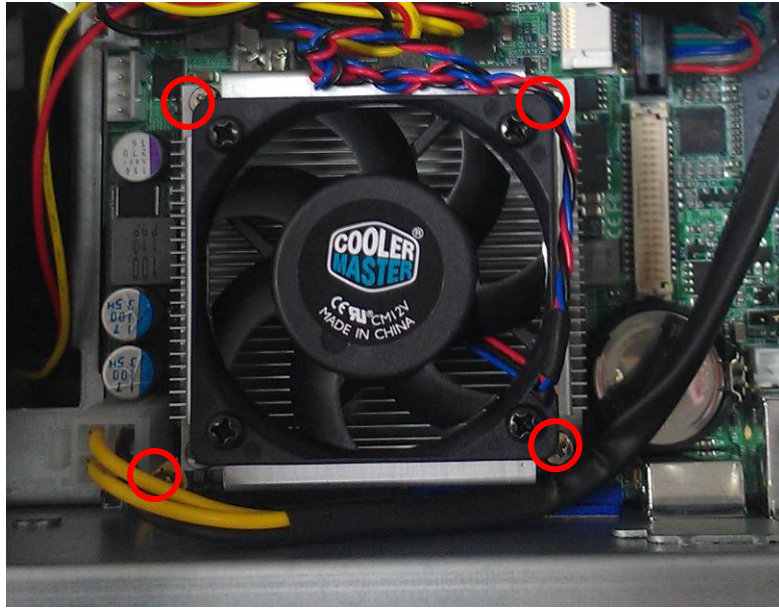

4. Screw off as indication of the picture below.

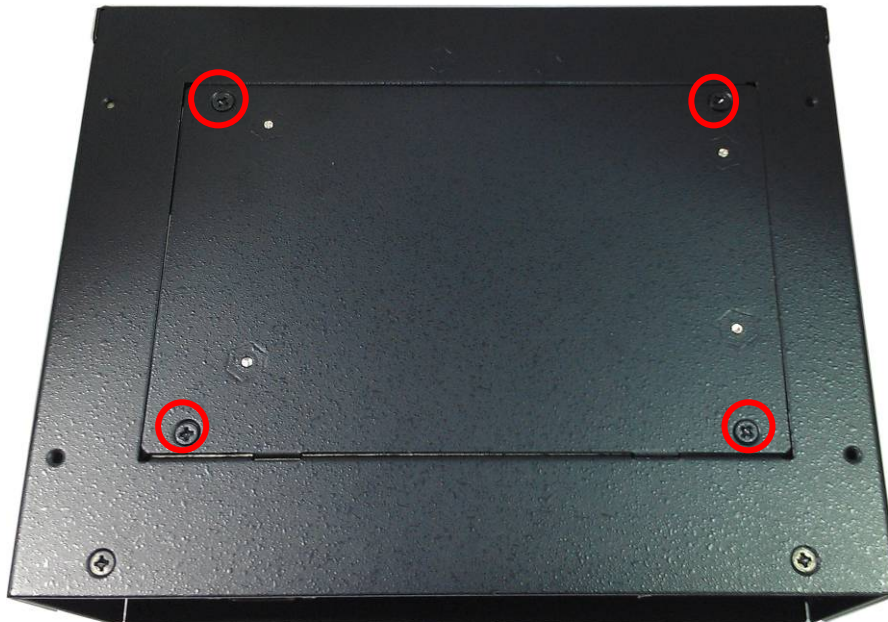

5. Insert the DDRII SO-DIMM module into the socket at 45 degree.
Press down the module with a click sound.

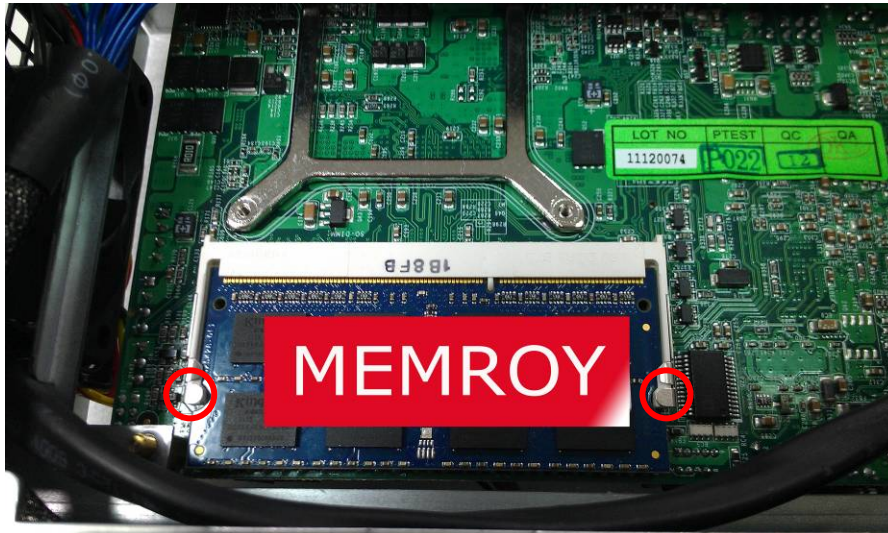
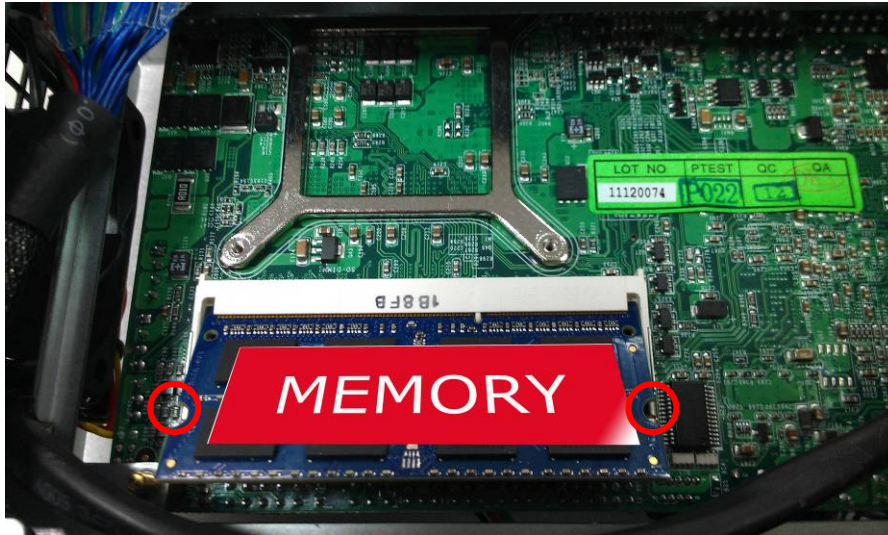

-
6. Put on HDD driver into HDD holder then turn the HDD drive screws to tighten.



7. Connect SATA cable to motherboard.

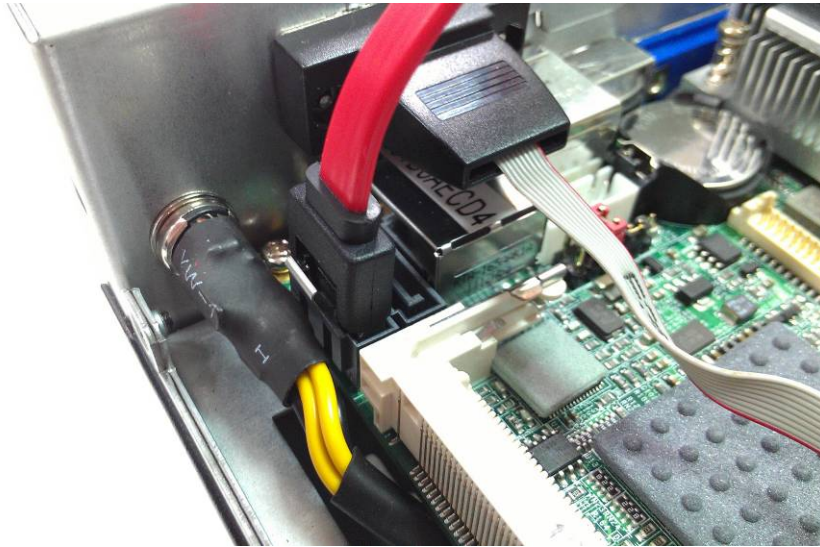

8. Put SATA cable holder through the motherboard holder.

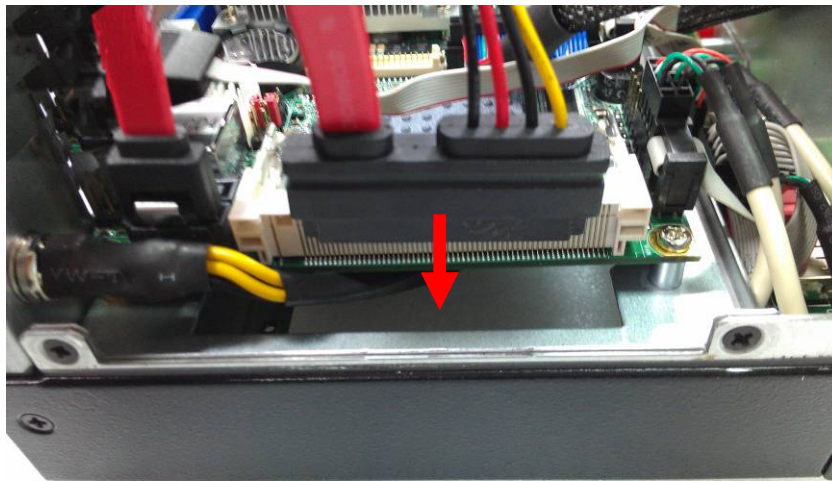

9. Connect SATA cable from motherboard to the HD drive.



10. Put the Chassis shield back and screw on as indication of the picture below Turn the screws.



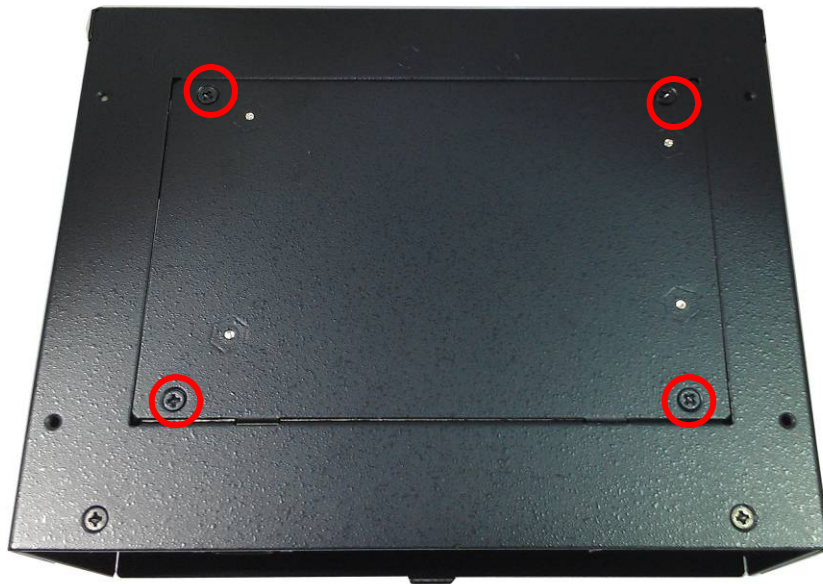

11. Put the top Chassis shield back and screw on as indication of the picture below.



12. Screw on as indication of the picture below.



13. Finish



Contact Information

Any advice or comment about our products and service, or anything we can help you please don't hesitate to contact with us. We will do our best to support you for your products, projects and business

Taiwan Commate Computer Inc.

Address	19F, No. 94, Sec. 1, Xintai 5th Rd., Xizhi Dist New Taipei City, Taiwan
TEL	+886-2-26963909
FAX	+886-2-26963911
Website	http://www.commell.com.tw
E-Mail	info@commell.com.tw (General Information) tech@commell.com.tw (Technical Support)
Facebook	https://www.facebook.com/pages/Taiwan-Commate-Computer-Inc/547993955271899
Twitter	https://twitter.com/Taiwan_Commate

Commell is a brand name of Taiwan Commate Computer Inc.